

Y7522DT Vapor Service Multivalve®

Y7522DT

Application

These compact Multivalves® are suited for vapor withdrawal of containers where compact groupings of components are necessary. Separate filler valves and pressure relief valves are required.

Features

- Combines service valve with a vapor equalizing valve, fixed liquid level gauge, optional manometer, includes regulatory pressure test port.
- Low profile design allows the use of small domes.
- Separate excess flow valve for vapor service outlet @50 or 90 Kg/Hr.

Materials

Body	Forged Brass
Handwheel	Aluminum Die Cast
Valve Stem	Brass
O-Ring	Resilient Rubber
Seta Disc (shutoff valve)	Nylon

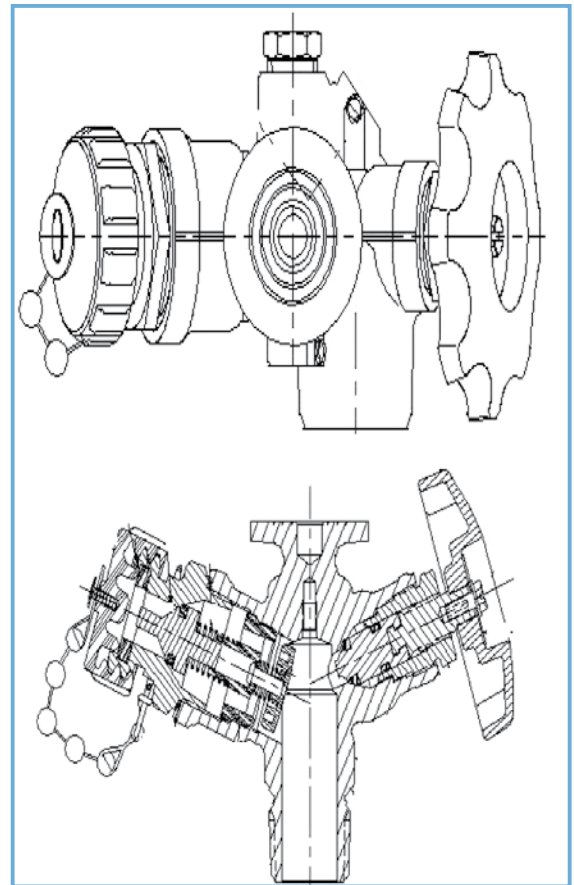

Ordering Information

Part Number	Container Connection	Service Connection	Vapor Equalizing Closing Flow Range	Fixed Liquid Level Vent Valve Style	Dip tube Length
Y7522DT	¾" M.NPTF	POL**	220 KG/HR	Needle Valve with retaining screw	*

* Dip tubes made to order, specify the required length when ordering. 12/11/07

** 3188WA &WB: POL X W20 1-1/4" LH Thread (Whitworth)

3188WA 50 KG/HR Closing Flow

3188WB 90 KG/HR Closing Flow

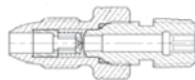

REGO GmbH - Distribution Center Europe
 Industriestrasse 9, D-35075 Gladenbach, Germany
 Phone +49 (0)6462-9147-0, Fax -9147-29
 info@rego-europe.de · www.rego-europe.de